

DETAIL A
1600 UNIT 3'-9" OVERHANG
ROOF SHEATHING PLACEMENT DETAIL
SHEATHING MATERIAL: 5/8" CDX PLYWOOD (18 PIECES OF EACH REQUIRED)
SCALE: 1/2"=1'-0"

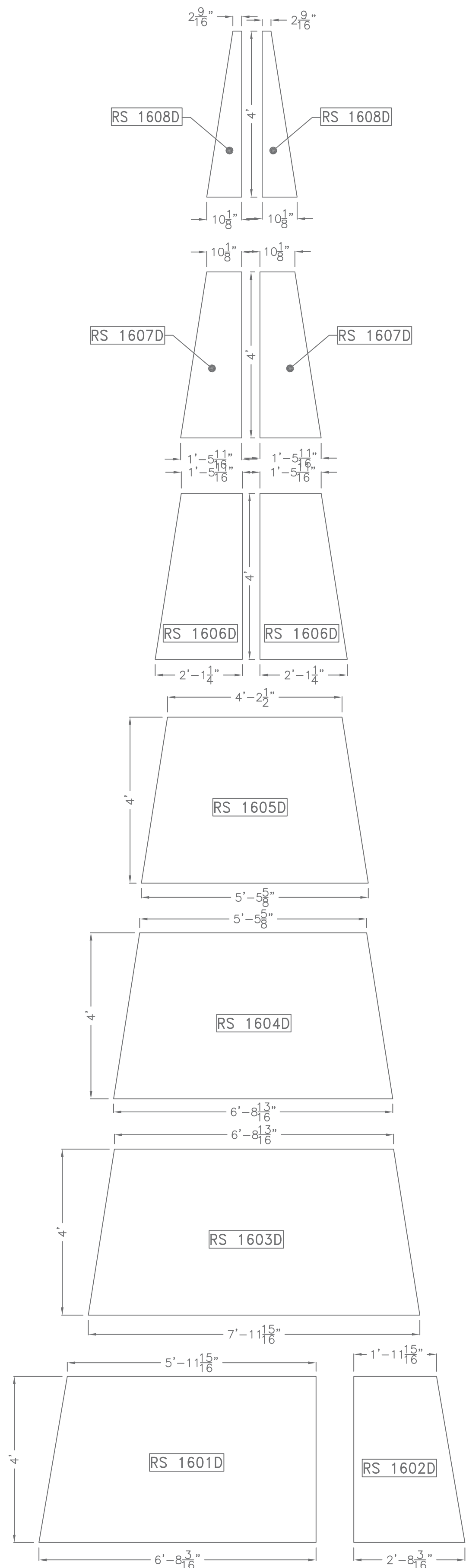

DETAIL B
1600 UNIT 3'-9" OVERHANG
ROOF SHEATHING COMPONENT DETAIL
SHEATHING MATERIAL: 5/8" CDX PLYWOOD (18 PIECES OF EACH REQUIRED)
SCALE: 1/2"=1'-0"

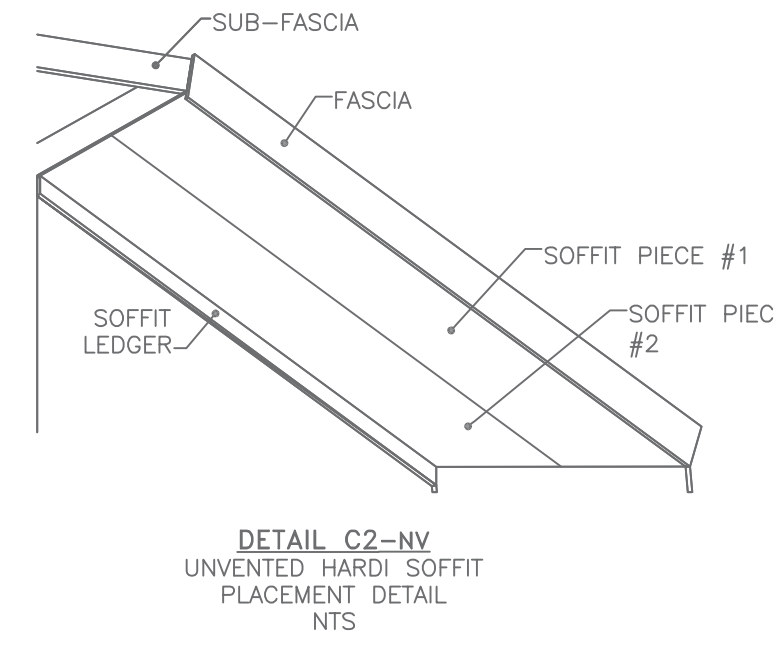

DETAIL C2-NV
UNVENTED HARDI SOFFIT
PLACEMENT DETAIL
NTS

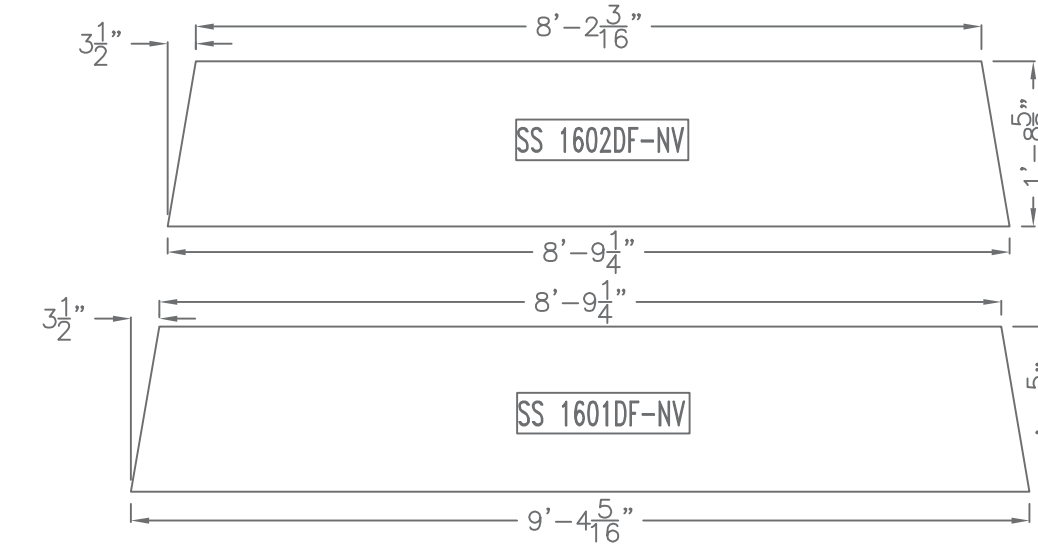

DETAIL D3-NV
1600 3'-9" OH
HARDI SOFFIT SHEATHING DETAIL
(UNVENTED WITH FOAM)
18 OF EA. REQUIRED

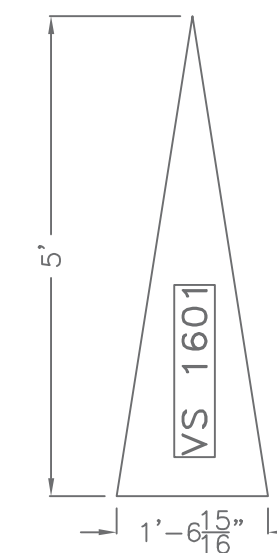

DETAIL E
1600 UNIT
CUPOLA SHEATHING COMPONENT DETAIL
SHEATHING MATERIAL: 5/8" CDX PLYWOOD
(18 PIECES OF EACH REQUIRED)
SCALE: 1/2"=1'-0"

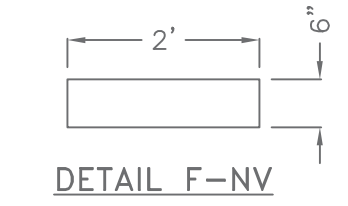

DETAIL F-NV
1600 UNIT
UNVENTED CUPOLA FASCIA COMPONENT DETAIL
(18 PIECES OF EACH REQUIRED)
SCALE: 1/2"=1'-0"

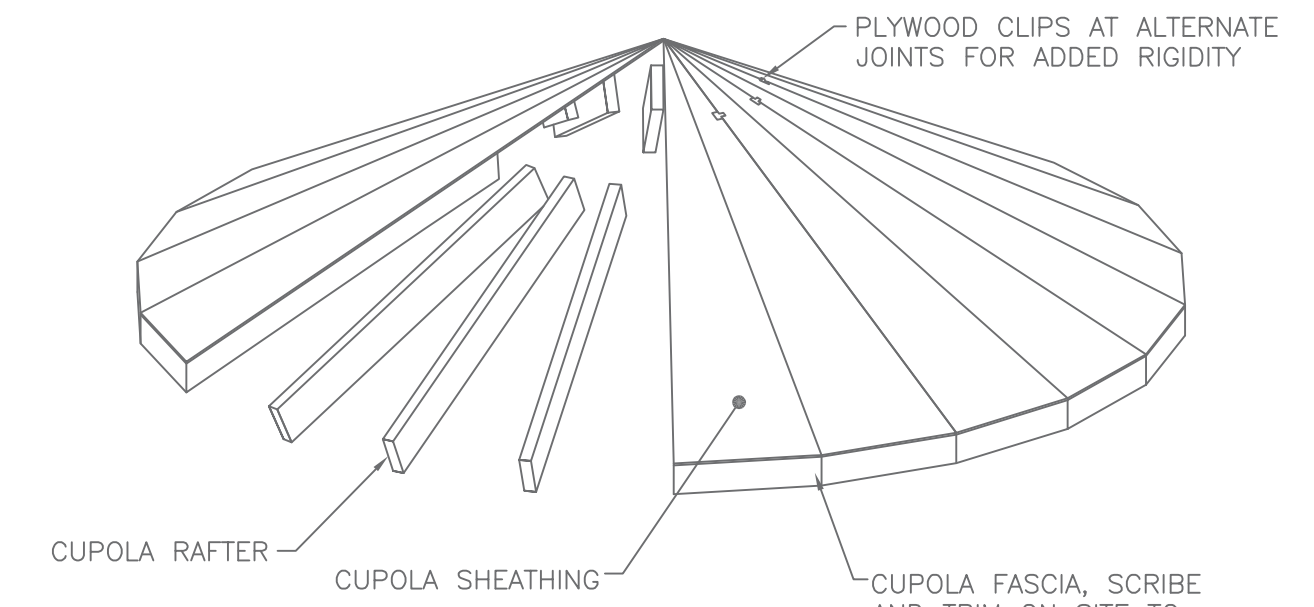

DETAIL D-NV
UNVENTED CUPOLA ILLUSTRATION
SCALE: NTS

DRAWING TITLE: ROOF SHEATHING & SOFFIT	
1600 3'-9" OVERHANG	
SCALE: AS NOTED	DRAWN BY: STAFF
DATE: 01/18/10	REVISION DATE: --
FILE LOCATION: K/GENS 2009/PAGE 8	



THIS DRAWING IS THE PROPERTY OF DELTEC HOMES. IT IS TO BE USED ONLY FOR THE PROJECT AND LOCATION SPECIFICALLY IDENTIFIED HEREON. ANY REUSE, REPRODUCTION, OR MODIFICATION OF THIS DRAWING WITHOUT THE WRITTEN PERMISSION OF DELTEC HOMES IS STRICTLY PROHIBITED. DELTEC HOMES ASSUMES NO LIABILITY FOR ANY ERRORS OR OMISSIONS. THE USER OF THIS DRAWING SHALL BE RESPONSIBLE FOR VERIFYING ALL DIMENSIONS AND CONDITIONS BEFORE CONSTRUCTION. © 2009 DELTEC HOMES.